

## VF300FAN ODOUR FILTER INSTALL INSTRUCTIONS

### **SAFETY ADVICE:**

**Keep out of reach of children**

Ensure adequate ventilation when removing filter from pack and installing.

Do not puncture the container or otherwise interfere with the product as this will reduce its effectiveness or produce harmful vapours.

### **First Aid Information:**

Poison Information Centre in each State capital city can provide additional assistance for

**Scheduled Poisons: Phone (Australia 13 1126)**

**Ingestion:** Rinse mouth with water. Do NOT induce vomiting. Seek medical assistance.

**Eyes & Skin:** Be careful to avoid contact with contents, or fumes from the filter as they may cause irritation to eyes, skin or breathing passages. If contact occurs wash affected area with plenty of water.

**Inhalation:** Remove victim from exposure. Remove contaminated clothing and loosen remaining clothing. Allow patient to assume most comfortable position and keep warm. Keep at rest until fully recovered.

**Seek medical advice if symptoms persist.**

---

### **OVERVIEW:** Designed to treat wastewater odour emissions.

Treated emissions exit through the top compartment via a mixed media cartridge.

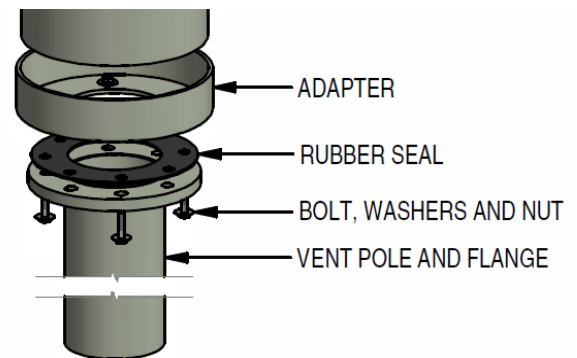
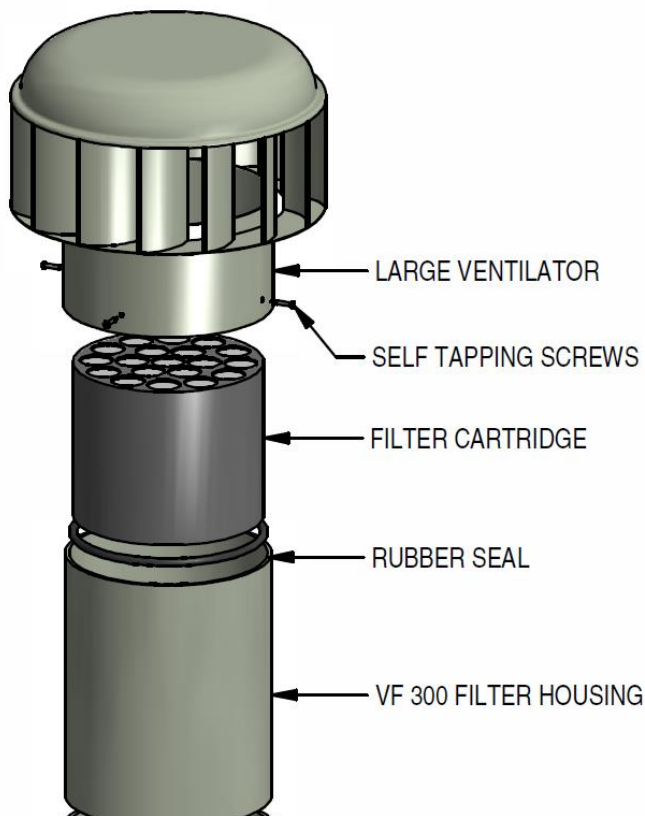

**Contact McBerns for Adapter and Vent Pole pricing.**

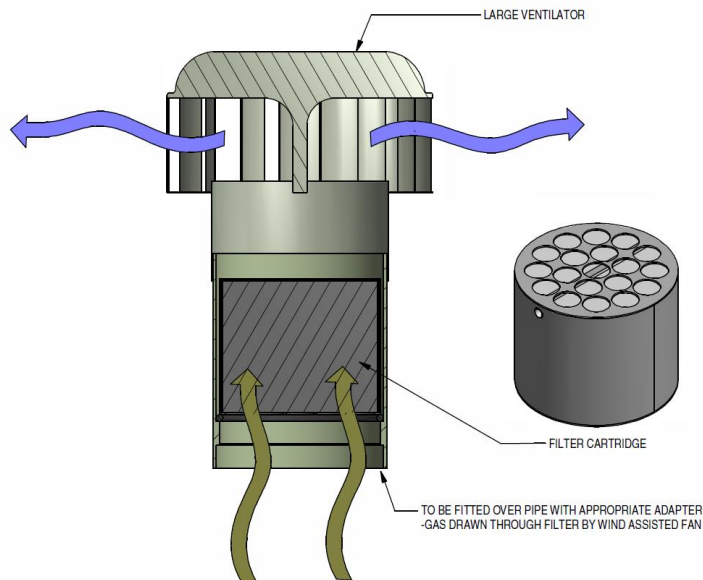

## **INSTALLATION**

**Appropriate PPE must always be worn**

1. The VF300FAN is designed for use with a vent pole or Vent Pipe, adapters are available for specific sizing (contact McBerns for pricing)
2. Apply a bead of hydroseal to the top of the rubber seal that the cartridge sits on, this is to create a seal between the cartridge and the rubber seal
3. Remove protective PVC seal from the cartridge, **ENSURE ALL PVC IS REMOVED**
4. Install cartridge "THIS WAY UP ↑" into Filter Housing, as per instructions on cartridge, rotate cartridge to seat/seal base to the rubber ring.
5. Fit Fan over the Filter Housing and secure with 2 x s/s screws supplied
6. The adaptor is now fitted to the base of the filter housing
7. Install VF300FAN securely to the vent pole/pipe and ensure all joints are sealed to eliminate any gases escaping

## **MAINTENANCE:**

The McBerns VF300FAN Odour Filter requires very little maintenance. We suggest:

1. Wipe down the outside of the unit every 3 months with a mild wash and wax solution this will maintain the paint work of the filter.
2. A check needs to be made of all the seals, ensuring that there is no splitting, leaks or cracking, if any deterioration occurs notify Person In Charge.
3. Using an odour measuring device check for Sulfide readings every 3 months, if levels are high contact Person In Charge.
4. Ensure all Fittings & Fastenings are secure
5. **When filter ceases to be effective replacement media cartridges are available.**

**Manufactured by:**  
**McBerns Pty Ltd (ABN 060984107)**  
**PO Box 304 Yandina Qld 4561 Australia**  
**Phone: 61 (0)7 54451646**  
**Fax: 61 (0)7 54451743**  
**Email: [mail@mcberns.com](mailto:mail@mcberns.com)**